

FRONT

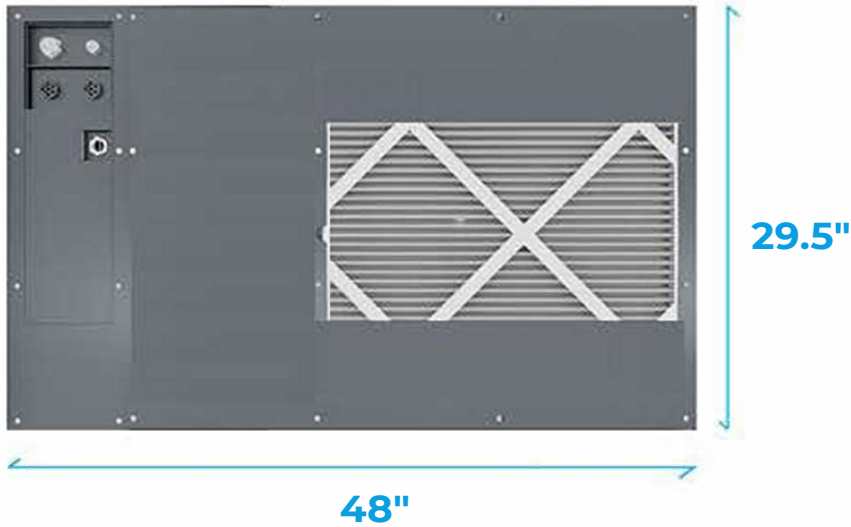

RETURN AIR OPENING 15" x 30.5"

EVOLUTION SERIES AIR HANDLER 3-TON HORIZONTAL (36,000 BTU)

VOLTAGE: 230 V 1/3 PHASE or SPECIAL 460 V 3-PHASE
SYSTEM AMPS: 1 PHASE FLA: 21.2 A MCA: 25 A MOP: 40 A
3 PHASE FLA: 16 A MCA: 20 A MOP: 30 A
460 V 3-PHASE FLA: 10.7 A MCA: 15 A MOP: 20 A

CAPACITOR: 14 UF
FAN TYPE: BACKWARD INCLINED
FAN DIAMETER: 26"
MATERIAL: COMPOSITE
RPM: 1070
FAN CFM: 3000
DB RATING: 69
COIL: 2 X SLAB MICROCHANNEL (DEHUMIDIFICATION)
COIL FACE: 21.5" X 36"
CAPACITY: 36,000 BTU
REFRIGERANT: R-410A
LIQUID LINE: 3/8" **DISCHARGE LINE:** 5/8"
CONTROL CONNECTION: 9-PIN TURN & LOCK
T-STAT CONNECTION: 9-PIN TURN & LOCK
WEIGHT: 260 LB

BACK / SIDE

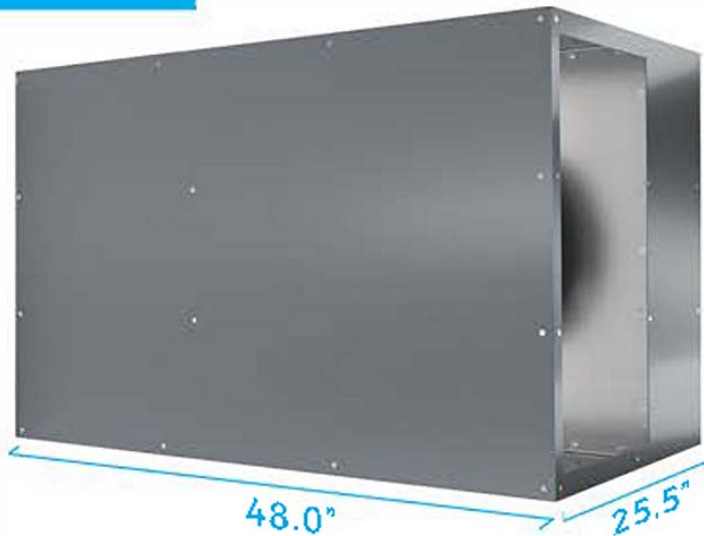

SUPPLY AIR OPENING 26.5" x 13.5"

NOTABLES:

COMPRESSOR IS LOCATED INSIDE THE AIR HANDLER.

ALL SYSTEM CONTROLS ARE LOCATED WITHIN THE ELECTRICAL PANEL.

ELECTRICAL PANEL CAN BE ORDERED FRONT OR BACK.

INTEGRATED CONDENSATE PUMP.

UNIT COMES IN BOTH PRE-CHARGED QUICK-CONNECT OR PRO SERIES HARD PIPED.

.STL FILES ARE AVAILABLE UPON REQUEST.

EXCEL AIR SYSTEMS
120-20170 STEWART CRES.
MAPLE RIDGE, BC V2X 0T4
CANADA

TEL/FAX: 1-877-728-0757
SALES@EXCELAIRSYSTEMS.COM

FRONT

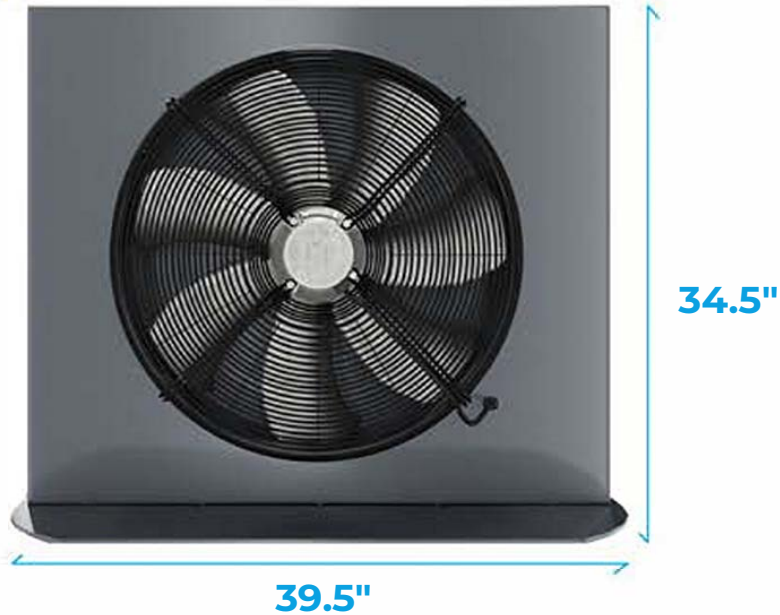

**EVOLUTION SERIES CONDENSER
3-TON (36,000 BTU)**

VOLTAGE: 230 V 1 PHASE
FAN AMPERAGE: 4.8 A (POWER SUPPLIED FROM AIR HANDLER)
CAPACITOR: 16 UF
FAN DIAMETER: 25"
MATERIAL: CAST WINGTIP
RPM: 990
FAN CFM: 4500
DB RATING: 55 / 62 / 69
COIL: SLAB MICROCHANNEL
COIL FACE: 30" X 30"
CAPACITY: 36,000 BTU
REFRIGERANT: R-410A
LIQUID LINE: 3/8" **DISCHARGE LINE:** 5/8"
CONTROL CONNECTION: 9-PIN TURN & LOCK
MODULATION: LOW AMBIENT CONTROLLER (-35 °F)
WEIGHT: 126 LB

SIDE



NOTABLES:

POWER IS SUPPLIED FROM INDOOR AIR HANDLER.
MINIMUM CLEARANCE FROM WALL IS 9".
CAN BE ELEVATED AND BRACKETED TO WALL.
UNIT COMES IN BOTH PRE-CHARGED QUICK-CONNECT
OR PRO SERIES HARD PIPED.
LOW AMBIENT SENSOR IS INTEGRATED
WITHIN THE COIL.
.STL FILES ARE AVAILABLE UPON REQUEST.

EXCEL AIR SYSTEMS
120-20170 STEWART CRES.
MAPLE RIDGE, BC V2X 0T4
CANADA

TEL/FAX: 1-877-728-0757
SALES@EXCELAIRSYSTEMS.COM